

Ascent Touch

Here in the Pacific Northwest, we're known for a couple of things: innovative technology that's simply reliable, and great tasting coffee. At Concordia, we join those forces.

Savor coffee the way that roast masters intend – ground fresh, brewed fresh, and tasting perfect every time. Our patented ALPS technology ensures perfectly dialed-in recipes, brewing in under 30 seconds, and an SCA Gold Cup standard with every brew.

By having separate grinders per bean hopper, The Ascent Touch allows fine-tuning all parameters per individual roast. Bring out the florals in a light roast and let the dark roast still shine!

You have full control over your offerings! Stock 4 different roasts, list 4 different sizes, list hot and iced, offer carafe options, and update new coffee descriptions. Ask us about customizing your branding on our 10" touchscreen.

Elevate your coffee program to new heights!



 **CONCORDIA**
SEATTLE BUILT

SCA Gold Standard Cup quality

Following Specialty Coffee Association standards, whole beans are ground and brewed for each cup, ensuring you get the best tasting, freshest brewed coffee every time, hot or iced.

Zero Waste with minimal consumables

Say goodbye to running out of filters, batches gone cold, and stale burnt flavor. Say hello to freshness that stays true to how the coffee was meant to taste.

What is ALPS Brewing Technology?





The Ascent Touch was designed to deliver the Gold Cup brewed coffee experience quickly, by brewing at lower pressures than traditional espresso machines. ALPS stands for Accelerated Low Pressure Steeping: our approach balances pressure, flow, and chamber design to create a coffee flavor, previously only matched by manual brewing. Unlike traditional brewing methods, the ALPS system requires no filters, preserving essential oils and aromas in the final cup.

Control brew recipes with adjustable functions.

- Grind volume
- Grind size
- Water volume
- Water temperature
- Brewing contact time
- Pre-Infusion

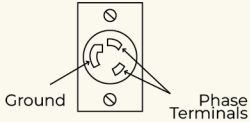
Remote IoT by Middleby's Open Kitchen	Simple daily cleaning and maintenance
ADA Touchpad	Brew chamber holds up to 40 grams of coffee
Brew 16oz in less than 30 seconds	Offer iced coffee options when paired with an ice machine
Compact design	Offer "with room" and "extra room" options
Brew 4 standard sizes (plus carafes!)	Can be supplied with two, three or four grinders/hoppers
Customize from 8oz to 96oz (237-2840ml) carafes	Customizable Recipes Per Brew
Ask us about our graphics package offerings	Ask us about Preventative Maintenance packages

Specifications

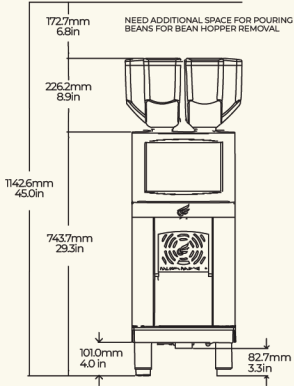
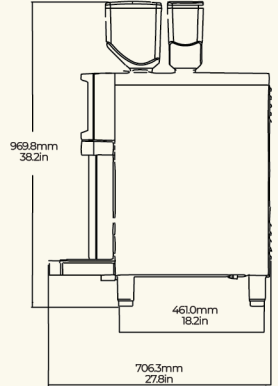
<p>Ascent Touch</p> <p>Dimensions 12.5" W x 27.8" D X 38.2" H</p> <p>Weight 125lbs net/57kg net</p> <p>Electric 200-240VAC 50/60Hz 30A Dedicated Circuit</p> <p>Water Min 25psi, Max 100psi, 25gal per/hr flow</p> <p>Drain 3/4" indirect drain OD of 1 1/4", drain within 5 ft.</p> <p>Shipping Specs 20" x 38" x 42" 200lbs</p>	<p>Site Electrical Requirements</p> <p>Plug Included is L6-30P Nema L6-30R Receptacle</p>  <p style="text-align: center;">    </p>	<p>Front View</p> 	<p>Side View</p> 
---	---	--	--

Note: Please refer to this model's installation checklist for more detailed information on site and consumable requirements.

Concordia units come with a standard 1 Year Parts and Labor warranty. Preventative Maintenance packages available with machine purchase.

800.778.0990
concordiacoffee.com